

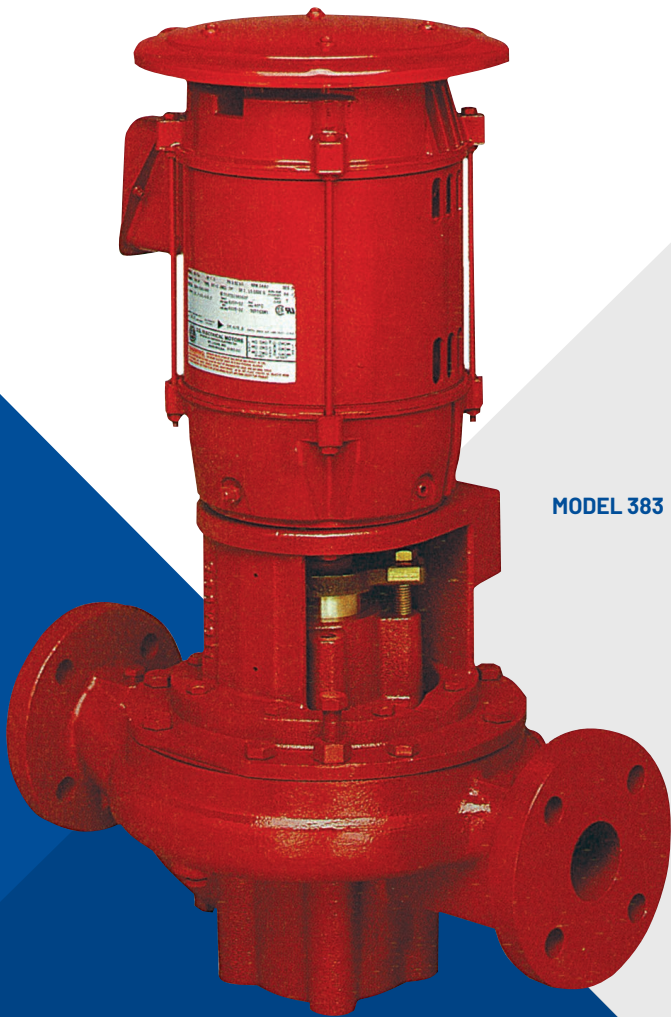

911 SERIES

VERTICAL IN-LINE FIRE PUMPS



MODEL 383

PENTAIR AURORA 911 SERIES VERTICAL IN-LINE FIRE PUMPS

Vertical in-line fire pumps are designed to save space in your mechanical room, with features that make it easier to service and maintain.

The vertical orientation lends itself to a smaller footprint. You can easily remove the motor bracket and assembly without disturbing the piping. With an impeller that's direct-coupled to the motor shaft for easier maintenance, it also minimizes run-out and reduces noise while running.

A heavily ribbed in-line casing helps resist pipe strain and can be supported to simplify mounting to a base or foundation. The back pull-out in-line case design simplifies disassembly because the suction and discharge piping or alignment are not disturbed as the casing remains in the pipeline. If you're ready for service or inspection, you can simply remove the motor and bracket assembly.

SUPERIOR PERFORMANCE

- ◆ Flows from 50 to 1500 GPM (11 to 340 m³/hr)
- ◆ Pressures from 40 to 155 psi (2.8 to 10.7 bar) and beyond
- ◆ Pump design optimized for low HP requirements

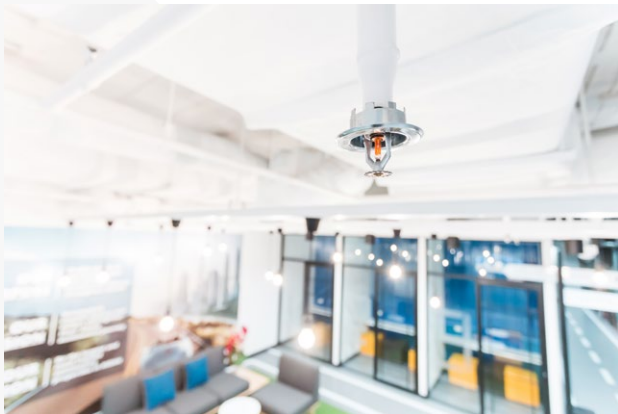

STANDARD

- ◆ Bronze-fitted pump construction
- ◆ Bronze shaft sleeve
- ◆ Split bronze packing gland
- ◆ Carbon steel shaft
- ◆ 125# ANSI flange drilling
- ◆ Dynamically balanced vacuum cast impeller
- ◆ Stainless steel impeller screw and washer
- ◆ Bronze case wearing ring(s)
- ◆ Graphite impregnated acrylic packing
- ◆ Motor: NEMA®-Hydraulic Institute®, JP or TCZ frame
- ◆ Factory performance tested in accordance with NFPA 20

ACCESSORIES

- ◆ Suction and discharge pressure gauges
- ◆ Air release valve
- ◆ Circulation relief valve
- ◆ Hose valve header
- ◆ Hose valves
- ◆ Flow meter
- ◆ Jockey pump
- ◆ Optional flange drillings
 - 125 lb. suction – 250 lb. discharge
 - 250 lb. suction and discharge

RED HOT FIRE PUMP QUICK SHIP PROGRAM

With lead times ranging from 10 to 20 business days for our most popular fire pump selections, you can schedule more jobs for critical applications.

To find more information and connect with an Authorized Distributor, visit pentair.com/aurora.

PUMP FEATURES

A. BACK PULL-OUT CASING

With in-line suction and discharge.

B. CASE WEAR RING

Prevents wear on casing and is easily and inexpensively replaced.

C. SUPPORT

Simplifies mounting. The pump can be fastened to the floor, a base or foundation.

D. DYNAMICALLY BALANCED IMPELLER

Is keyed to the shaft and secured by a capscrew and washer. Vacuum casting and quality controlled manufacturing process assures consistent high performance. Enclosed design provides high efficiency and low wear for long service life.

E. CARBON STEEL SHAFT

Is designed for minimum deflection at maximum load.

F. TWO PIECE BRONZE PACKING GLAND

Provides easy packing maintenance.

G. FACTORY PERFORMANCE TEST

Guarantees performance at specified pump operating conditions.

H. FLUSH LINE

With valve (when used) from discharge provides easy water seal adjustment to lantern ring.

I. BRONZE SHAFT SLEEVE

Extends full length of stuffing box to protect motor shaft. The shaft sleeve is slip fit over the shaft and then is keylocked. Shaft sleeve and impeller screw are sealed by O-ring gaskets to eliminate corrosion of the shaft by the pumped liquid.

J. STANDARD MOTOR

Approved for 911 Series pump service by NEMA® and the Hydraulic Institute® provides low noise level pump operation.

K. VOLUTE TYPE SUCTION

Inlet pre-rotates suction liquid.

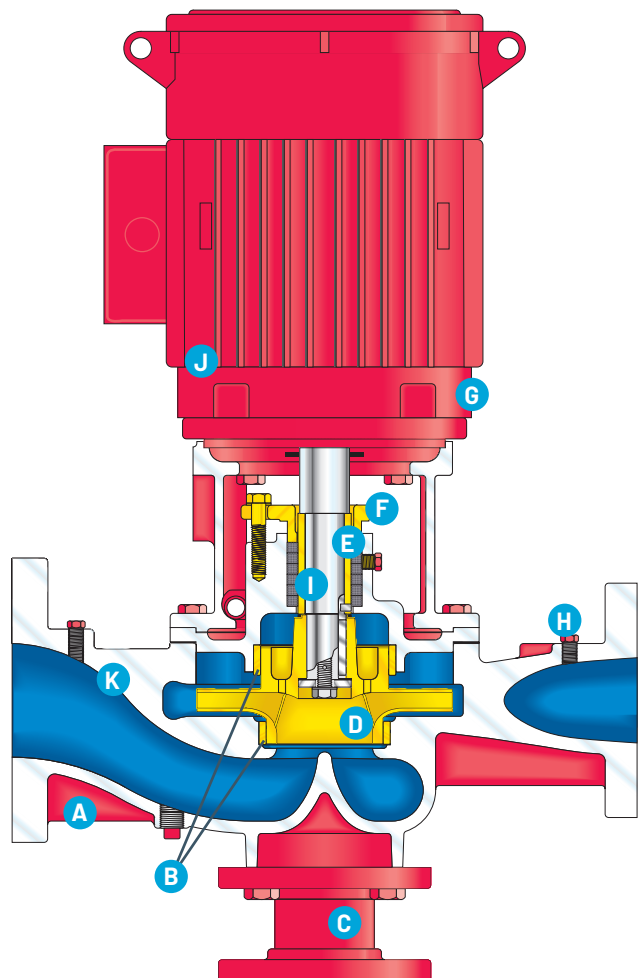

NOTE: Front case wearing rings are standard on all size pumps. Rear case rings are standard on all sizes except the 2x2x9C. The 2x2x9C does not require a wear ring.



YOUR PUMP PARTNER FOR THE WHOLE BUILDING

Protecting legacies like yours for more than a century

Our extensive pump portfolio, crafted with a tradition of quality and excellence, has countless applications in commercial buildings. Whether it's fire suppression for safety or HVAC and boosting applications for comfort, your building is covered with dynamic water movement solutions that fit your needs.

No matter where it's used, you can trust that your pump is backed by a dedicated team providing unwavering support throughout its lifetime.

Because every decision counts when selecting pump equipment that protects your building and the people inside.



EXPLORE OUR PUMP PORTFOLIO

FIRE SUPPRESSION • HVAC
PRESSURE BOOSTING



800 Airport Road | North Aurora, IL 60542 | USA | PH: 630.859.7000 | pentair.com/aurora

Hydraulic Institute is a registered trademark of Hydraulic Institute, Inc.
NEMA® is the registered trademark and service mark of the National Electrical Manufacturers Association.
All FM Approvals certification marks are the sole property of FM Approvals LLC.
UL and the UL logo are trademarks of UL LLC.

All indicated Pentair trademarks and logos are property of Pentair. Third party registered and unregistered trademarks and logos are the property of their respective owners.

©2024 Pentair. All Rights Reserved.

AF-02-1034 (08-26-24)